

OVAL 3 STONES

PANADERO



MAßE

MAßE H x B x T	1048x605x490mm
GEWICHT BRUTTO/NETTO	195/180 kg
MAßE FEUERRAUMTÜR	355x440 mm
DURCHMESSER DES ABGASSTUTZEN	Ø 150-153 mm Oben
EXTERNE LUFTZUFUHR	Ø 80 mm

EIGENSCHAFTEN

ROST AUS GUSSEISEN	
NENNLEISTUNG	8,7 KW
WIRKUNGSGRAD	80,7 %
CO - EMISSIONEN	0,12 %
HITZESCHUTZANSTRICH	800°C
GLASKERAMIKSCHEIBE HITZEBESTÄNDIG BIS	750°C

EAN 8426964183153
REF. PANADERO 18315

PRODUKT PLUS

ECODESIGN



**EXTERNE
LUFTZUFUHR**



260
m³ RAUMHEIZVERMÖGEN



VERMICULIT
AUSKLEIDUNG



SCHEIBENSPÜLUNG



DREIFACHVERBREN-
NUNG



SCHEITLÄNGE 50 CM



HOLZFACH



DOPPELBLECHGEHÄUSE
4 + 2 MM



NATURSTEIN

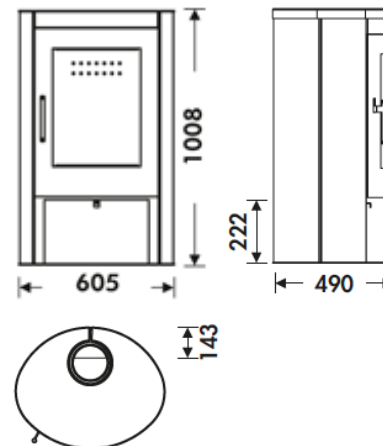

OVAL 3S DE

